

B O A R D O F S T U D I E S
NEW SOUTH WALES

2009

**HIGHER SCHOOL CERTIFICATE
EXAMINATION**

Physics

General Instructions

- Reading time – 5 minutes
- Working time – 3 hours
- Write using black or blue pen
- Draw diagrams using pencil
- Board-approved calculators may be used
- A data sheet, formulae sheets and Periodic Table are provided at the back of this paper
- Write your Centre Number and Student Number at the top of pages 9, 11, 13, 15, 19 and 21

Total marks – 100

Section I Pages 2–22

75 marks

This section has two parts, Part A and Part B

Part A – 15 marks

- Attempt Questions 1–15
- Allow about 30 minutes for this part

Part B – 60 marks

- Attempt Questions 16–27
- Allow about 1 hour and 45 minutes for this part

Section II Pages 23–33

25 marks

- Attempt ONE question from Questions 28–32
- Allow about 45 minutes for this section

Section I
75 marks

Part A – 15 marks

Attempt Questions 1–15

Allow about 30 minutes for this part

Use the multiple-choice answer sheet for Questions 1–15.

- 1** A fast-moving space probe passes close to a planet.

During its journey, how does the gravitational field of the planet affect the speed and direction of the probe?

	<i>Speed</i>	<i>Direction</i>
(A)	Remains constant	Remains constant
(B)	Remains constant	Changes
(C)	Changes	Changes
(D)	Changes	Remains constant

- 2** A satellite is moving in a circular orbit of radius 7.0×10^6 m around Earth.

If the speed of the satellite is 8.1×10^3 m s⁻¹, what is its centripetal acceleration?

- (A) 9.4 m s⁻²
(B) 9.8 m s⁻²
(C) 5.6×10^{25} m s⁻²
(D) 3.9×10^{32} m s⁻²
- 3** A satellite is moved from a geostationary orbit to a higher orbit.
- Which statement about the orbit change is correct?
- (A) During the move the gravitational potential energy decreases.
(B) The change in gravitational potential energy is independent of the mass of the satellite.
(C) The work done is the difference between the gravitational potential energy of the higher orbit and that of the geostationary orbit.
(D) The work done is the energy required to move the satellite, which is in the gravitational field, from a very large distance away, to the higher orbit.

- 4 A device launches two identical balls (x and y) simultaneously in a horizontal direction from the same height. The results are shown.

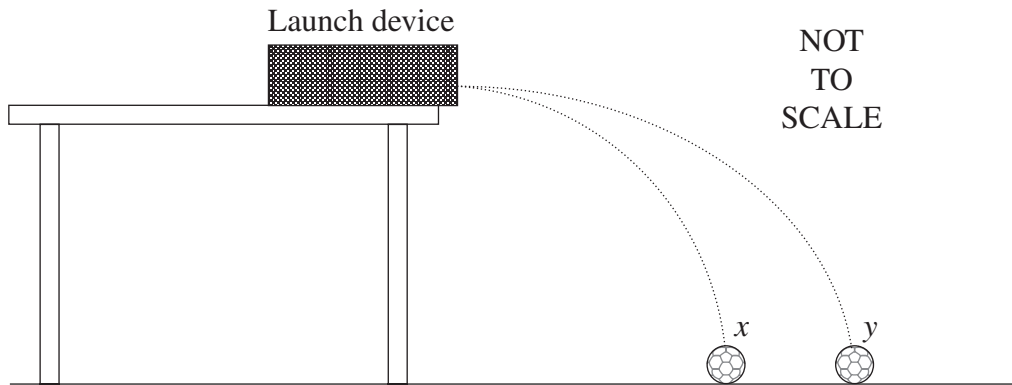

Which statement correctly describes what happens?

- (A) x hits the ground before y as it is closer to the launch site.
 - (B) y hits the ground before x as it has a higher launch velocity.
 - (C) x and y hit the ground simultaneously with the same velocity.
 - (D) x and y hit the ground simultaneously with different velocities.
- 5 During a lunar eclipse, Earth moves between the Sun and the Moon.



What happens to the force exerted by the Sun on the Moon?

- (A) It increases.
- (B) It decreases.
- (C) It remains unchanged.
- (D) It depends on the closeness of Earth to the Moon.

- 6 Which of the following would increase the output of a simple DC generator?
- (A) Increasing the rotation speed of the rotor
 - (B) Reducing the number of windings in the coil
 - (C) Using slip rings instead of a split ring commutator
 - (D) Wrapping the windings around a laminated, aluminium core

- 7 A type of car speedometer consists of a rotating bar magnet which produces eddy currents in a copper disc. A model of this is shown.

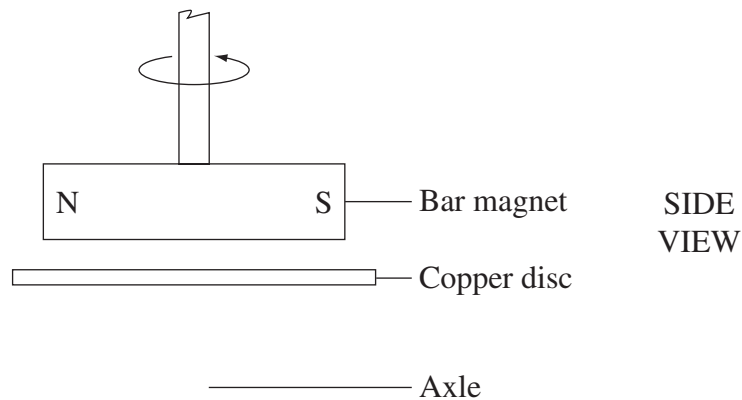

As the magnet begins to rotate, in which direction does the disc move?

- (A) Toward the magnet
 - (B) Away from the magnet
 - (C) Rotates in the same direction as the magnet
 - (D) Rotates in the opposite direction to the magnet
- 8 What is an essential requirement for the operation of a step-down transformer?
- (A) A laminated iron core
 - (B) A non-conducting core
 - (C) A magnetic interaction between the primary and secondary coils
 - (D) An electrical connection between the primary and secondary coils

- 9 A thin solid conductor with sides $PQRS$ is moving at constant velocity v , at right angles to a uniform magnetic field B , directed into the page as shown.

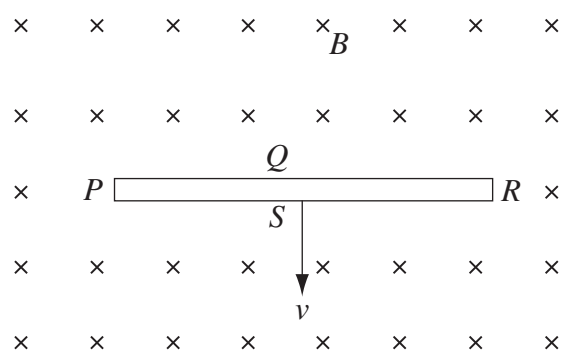

Which side of the conductor has the greatest concentration of electrons?

- (A) P
 (B) Q
 (C) R
 (D) S
- 10 Which option best identifies why germanium was replaced by silicon in the semiconductor industry?

	<i>Germanium</i>	<i>Silicon</i>
(A)	Remains a useful semiconductor at higher temperatures	Less abundant
(B)	Less abundant	Remains a useful semiconductor at higher temperatures
(C)	Remains a useful semiconductor at higher temperatures	More abundant
(D)	More abundant	Remains a useful semiconductor at higher temperatures

- 11 The diagram shows a DC motor with a constant current flowing to the rotor.

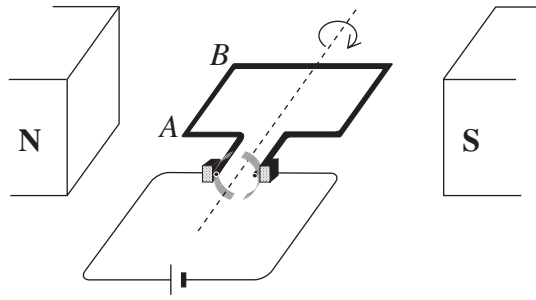

Which pair of graphs best describes the behaviour of the force F on wire AB , and the torque τ on the rotor as functions of time t ?

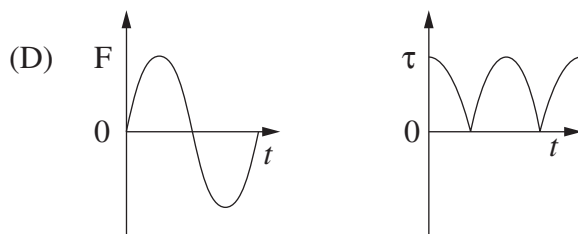
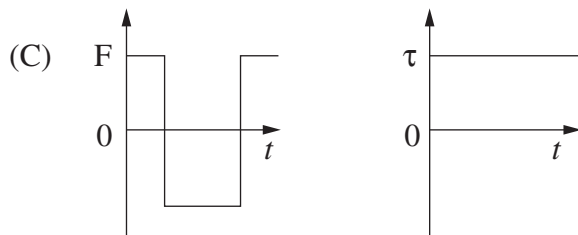
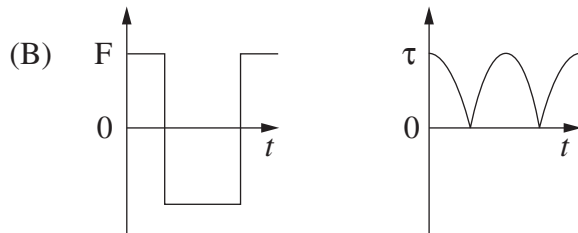
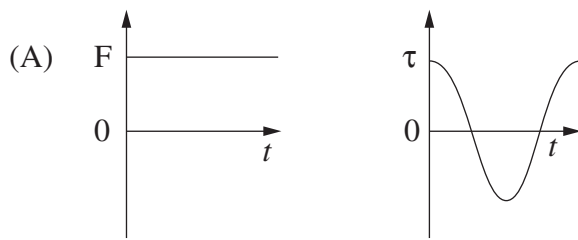

12 Which of the following diagrams best represents the energy bands in p -type and n -type semiconductors?

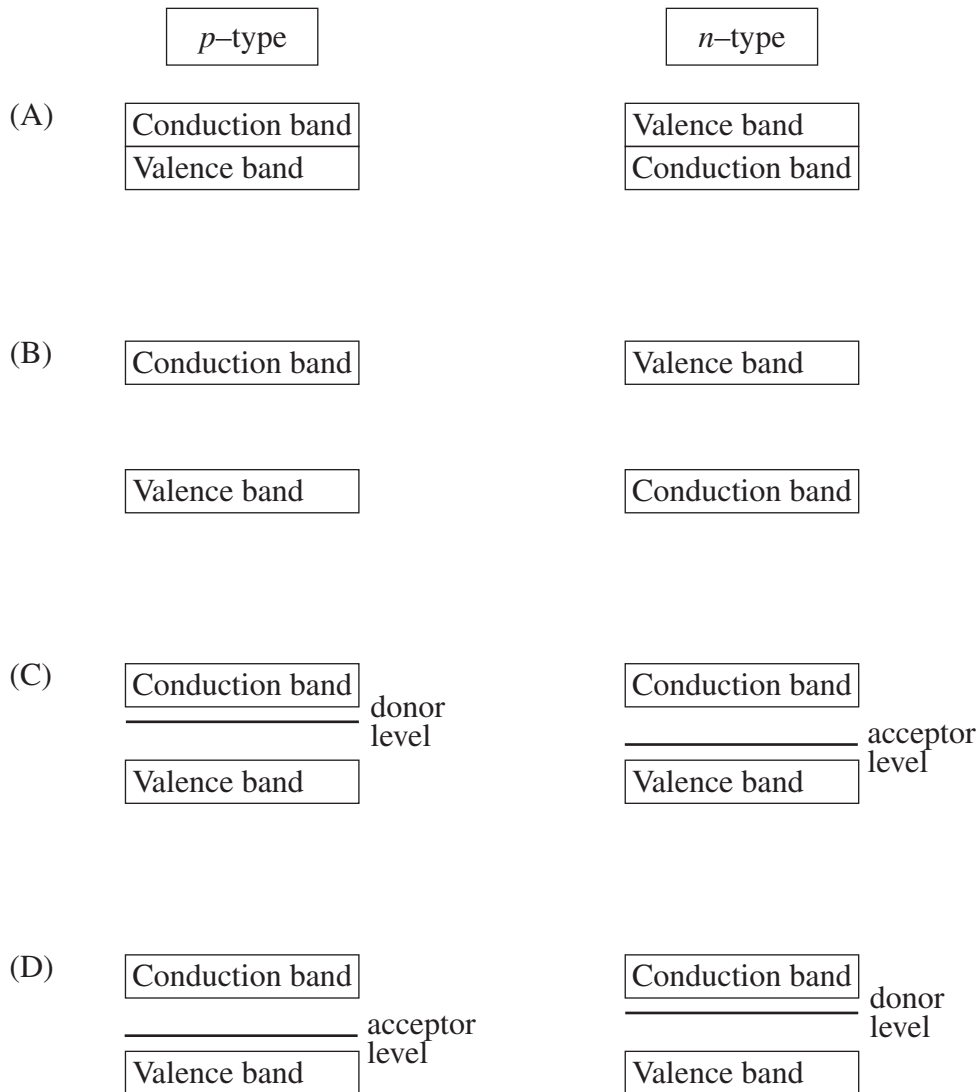

13 Why does superconductivity occur in certain materials at low temperatures?

- (A) At low temperatures there are no lattice vibrations.
- (B) Some pairs of electrons experience net attraction at low temperatures.
- (C) The materials are alloys and alloys lose all resistance at low temperatures.
- (D) At low temperatures the materials become magnetic and this reduces the scattering of electron pairs.

- 14 Blue light is found to cause photoelectric emission from a sodium surface but not from a platinum surface.

Which of the following best accounts for this difference?

- (A) Platinum does not absorb photons.
 (B) Platinum has more electrons than sodium.
 (C) More energy is needed to remove an electron from a platinum surface.
 (D) The intensity of the blue light is not high enough to remove electrons from the platinum surface.
- 15 The diagram shows two parallel plates with opposite charges. P , Q and R represent distances from the positive plate.

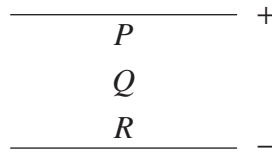

Which of the following graphs describes the electric field strength, E , between the plates?

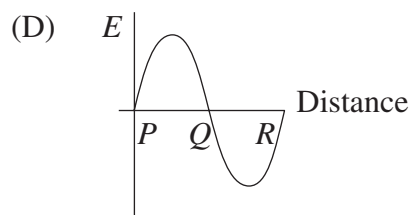
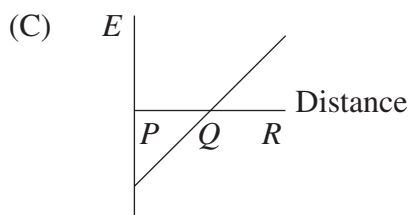
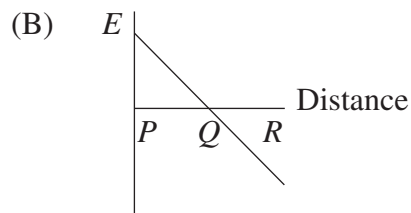
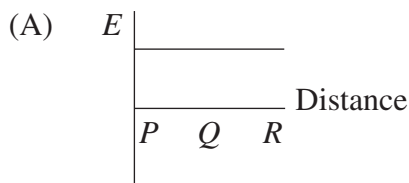

--	--	--	--	--

Centre Number

Section I (continued)

--	--	--	--	--	--	--	--	--

Student Number

Part B – 60 marks

Attempt Questions 16–27

Allow about 1 hour and 45 minutes for this part

Answer the questions in the spaces provided.

Show all relevant working in questions involving calculations.

Question 16 (3 marks)

NASA recently landed a space probe on an asteroid found between the orbits of Earth and Mars. The 500 kg space probe had a weight of 2.5 N when it landed on the asteroid.

- (a) What would be the weight of this space probe on the surface of Earth? 1

.....

.....

- (b) Before landing on the asteroid, the space probe was placed in an orbit with radius 50 km. The orbital period was 5.9×10^4 s. 2

What was the mass of the asteroid?

.....

.....

.....

Question 17 (5 marks)

- (a) Using labelled diagrams, show how a first-hand investigation could be performed to distinguish between an inertial and a non-inertial frame of reference. **2**

- (b) Explain how inertial and non-inertial frames of reference relate to the principle of relativity. **3**

.....

.....

.....

.....

.....

.....

.....

.....

.....

.....

--	--	--	--	--

Centre Number

Section I – Part B (continued)

--	--	--	--	--	--	--	--	--

Student Number

Question 18 (4 marks)

The nearest galaxy to ours is the Large Magellanic Cloud, with its centre located 1.70×10^5 light years from Earth. Assume you are in a spacecraft travelling at a speed of $0.99999c$ toward the Large Magellanic Cloud.

- (a) In your frame of reference, what is the distance between Earth and the Large Magellanic Cloud? **2**

.....

.....

.....

.....

- (b) In your frame of reference, how long will it take you to travel from Earth to the Large Magellanic Cloud? **2**

.....

.....

.....

.....

Question 19 (6 marks)

An electron is emitted from a mineral sample, and travels through aperture A into a spectrometer at an angle of 60° with a speed of $6.0 \times 10^6 \text{ m s}^{-1}$.

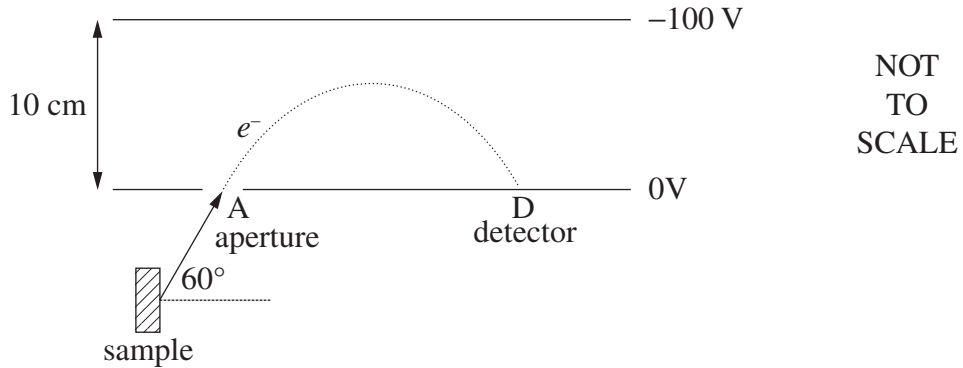

- (a) Calculate the magnitude and direction of the force experienced by the electron inside the spectrometer. **3**

.....

.....

.....

.....

.....

.....

- (b) The electron experiences constant acceleration and eventually strikes the detector, D. **3**

What is the time taken for the electron to travel from A to D?

.....

.....

.....

.....

.....

.....

--	--	--	--	--

Centre Number

Section I – Part B (continued)

--	--	--	--	--	--	--	--	--

Student Number

Question 20 (4 marks)

Draw a table to summarise the energy transformations and transfers for three household appliances. Each appliance must have a different type of useful energy output. Include the name of the appliance, its use and the transformation/transfer of energy involved.

4

--

Question 21 (6 marks)

A rectangular wire loop is connected to a DC power supply. Side X of the loop is placed next to a magnet. The loop is free to rotate about a pivot.

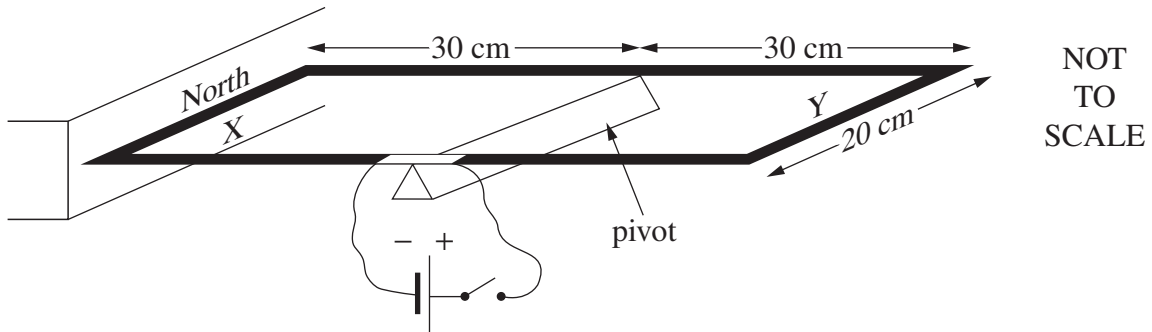

When the power is switched on, a current of 20 A is supplied to the loop. To prevent rotation, a mass of 40 g can be attached to either side X or side Y of the loop.

- (a) On which side of the loop should the mass be attached to prevent rotation? **1**

.....

- (b) Calculate the torque provided by the 40 g mass. **2**

.....

- (c) Calculate the magnetic field strength around side X. **3**

.....

--	--	--	--	--

Centre Number

Section I – Part B (continued)

--	--	--	--	--	--	--	--	--

Student Number

Question 22 (4 marks)

How did the invention of the transistor transform the way communication occurs in Australia? In your answer, refer to the technology that the transistor replaced. **4**

.....

.....

.....

.....

.....

.....

.....

.....

.....

Question 23 (6 marks)

Two identical wires, W_1 and W_2 , each 2.5 m in length, are positioned as shown. They carry identical currents in the direction indicated.

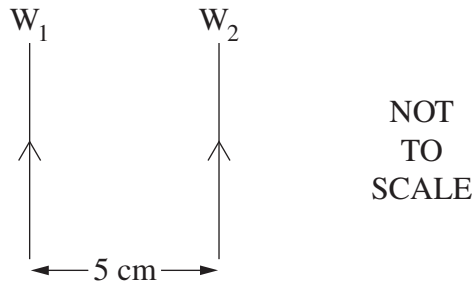

- (a) Identify the direction of the force which W_2 experiences as a result of the current in W_1 . **1**

.....

- (b) Calculate the current in each wire, given that the two wires experience a force of 6.9×10^{-4} N. **2**

.....

- (c) A third wire, W_3 , carrying a smaller current, is now placed as shown. **3**

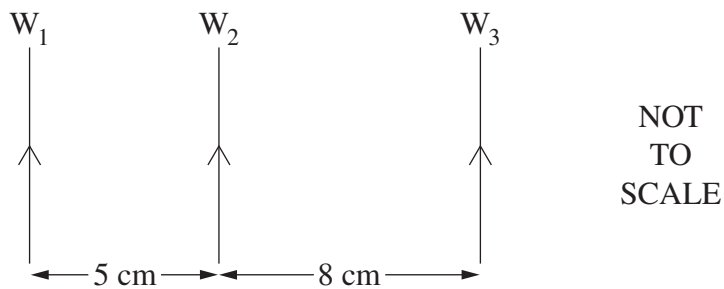

Explain qualitatively the forces on W_2 as a result of the currents in W_1 and W_3 .

.....

Question 24 (4 marks)

An experiment was conducted to investigate the flexibility* and strength** of different types of rubber bands, all with the same initial length. A mass was attached to each band and the extension was measured. Masses were gradually increased, and the extensions measured until each band broke. The photograph was taken during the experiment. The results are summarised in the graph.

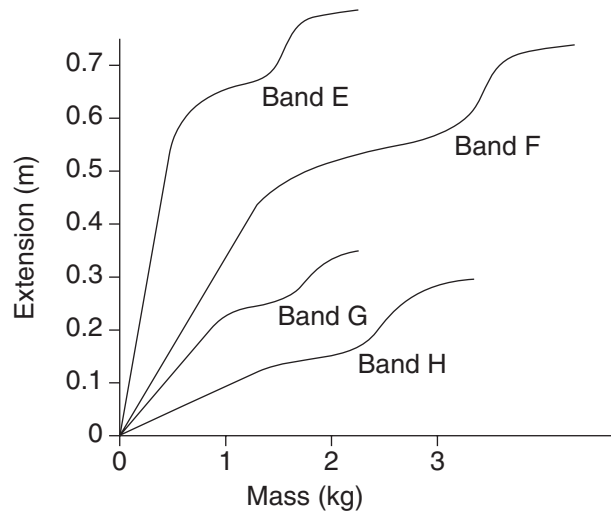

* Flexibility: *The more flexible the rubber band, the greater its extension for a given mass.*
** Strength: *The stronger the rubber band, the more mass it is able to hold before breaking*

- (a) Which rubber band is the most flexible? Justify your answer with reference to the graph. **2**

.....
.....

- (b) Identify the strongest rubber band and state the mass range in which the extension appears to be directly proportional to the attached mass. **2**

.....
.....

BLANK PAGE

--	--	--	--	--

Centre Number

Section I – Part B (continued)

--	--	--	--	--	--	--	--	--

Student Number

Question 25 (5 marks)

In the Large Hadron Collider (LHC), the particle beams are steered using magnetic fields, as shown.

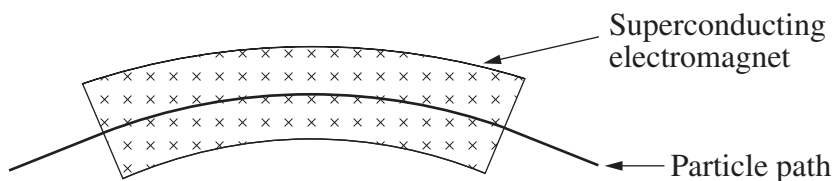

- (a) Two particles with the same mass and speed are travelling through the LHC in opposite directions. 2

What can be deduced about the charge on the particles?

.....
.....

- (b) During a test run, a proton travels with a speed of $1.0 \times 10^7 \text{ m s}^{-1}$ around the LHC. The radius of curvature of its path is 4.2 m. 3

Calculate the magnetic field strength.

.....
.....
.....
.....
.....
.....

--	--	--	--	--

Centre Number

Section I – Part B (continued)

--	--	--	--	--	--	--	--	--

Student Number

Question 27 (7 marks)

In an experiment to investigate the photoelectric effect, light is shone onto a silver surface and the resulting maximum electron kinetic energy is measured and recorded.

<i>Light wavelength (nm)</i>	<i>Electron kinetic energy (eV)</i>
250	0.25
215	1.08
187	1.90
167	2.73
150	3.56

- (a) Determine the frequency of the highest energy photons used in the experiment. **2**

.....

.....

.....

.....

- (b) What effect would changing the intensity of the light have on the measured electron kinetic energy? **1**

.....

.....

Question 27 continues on page 22

Question 27 (continued)

- (c) With reference to the photoelectric effect, and the semiconductors shown in the diagram, explain the operation of a solar cell.

4

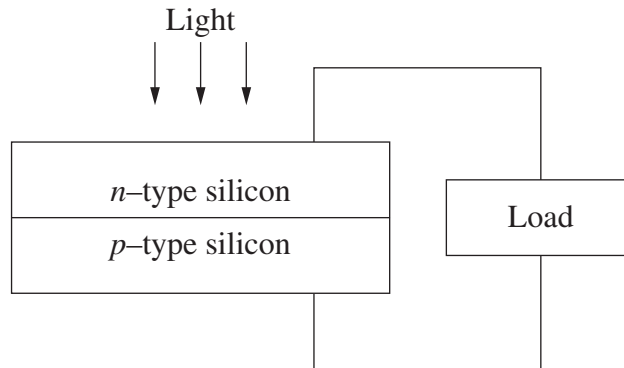

.....

.....

.....

.....

.....

.....

.....

.....

.....

.....

.....

.....

.....

.....

.....

.....

End of Question 27

Physics

Section II

25 marks

Attempt ONE question from Questions 28–32

Allow about 45 minutes for this section

Answer the question in a writing booklet. Extra writing booklets are available.

Show all relevant working in questions involving calculations.

	Pages
Question 28 Geophysics	24–25
Question 29 Medical Physics	26–27
Question 30 Astrophysics	28–29
Question 31 From Quanta to Quarks	30–31
Question 32 The Age of Silicon	32–33

Question 28 — Geophysics (25 marks)

- (a) Radiation is used to obtain information about a surface from a distance.
- (i) Use a labelled diagram and text to outline a first-hand investigation to demonstrate the relationship between the nature of a surface and the radiation reflected. **2**
 - (ii) How would the results demonstrate the relationship between the nature of the surface and the radiation reflected? **2**
 - (iii) Use a specific example to show how radiation can be used to provide information about Earth from a distance. **2**

- (b) A pendulum was used to determine the acceleration due to gravity, g , at the base of a mountain. The period, T , was 2.00 s, and the length of the string, l , was 1.00 m.

- (i) Calculate g , using the formula, **2**

$$T = 2\pi\sqrt{\frac{l}{g}}.$$

- (ii) Calculate the radius of Earth using this value of g . **2**
- (iii) The pendulum was moved to a different location where there are no mountains. The same value of T was obtained. **3**

Explain this observation.

Question 28 continues on page 25

Question 28 (continued)

- (c) Seismograms from three different geophysical stations showing the records of a small earthquake somewhere in California are shown. Time is marked on each seismogram by offsets in the records. The interval between the offsets is 1 minute.



- (i) Explain the features of the graphs and what information can be deduced. **3**
- (ii) Describe how seismic methods are used in the search for oil and gas. **3**
- (d) Name **THREE** geophysical techniques, and explain how each of these provides evidence to support the claim that Earth is dynamic. **6**

End of Question 28

Question 29 — Medical Physics (25 marks)

- (a) (i) In X-ray images, the small intestine is not normally visible. **2**
Explain how the use of a contrast medium, for example a barium meal, allows the small intestine to be seen.
- (ii) Using text and a labelled diagram, explain how X-rays are produced for medical imaging. **4**
- (b) (i) Given the velocity of sound in blood is $1.53 \times 10^3 \text{ m s}^{-1}$, and blood has a density of $1.05 \times 10^3 \text{ kg m}^{-3}$, calculate the acoustic impedance of blood. **1**
- (ii) Ultrasound can pass from blood into a variety of materials. What happens to the incident pulse when it passes into materials of increasing acoustic impedance? **1**
- (iii) Explain how a piezoelectric crystal can be used as a producer and receiver of ultrasound waves. **4**

Question 29 continues on page 27

Question 29 (continued)

- (c) (i) “Have a CAT scan – live longer!” **4**

Can the claim made in this statement be justified? In your answer refer to the properties and uses of CAT scans.

- (ii) In this PET image a chemical tracer has been used to measure glucose metabolism in a patient. **3**



Awaiting Copyright

Explain how this image has been produced, including the physics involved.

- (d) Describe the sequence of events and associated processes of physics by which an image is produced using magnetic resonance imaging. **6**

End of Question 29

Question 30 — Astrophysics (25 marks)

(a) (i) Distinguish between the terms *resolution* and *sensitivity* as used in astrophysics. **2**

(ii) Interferometry and active optics are techniques that can be used to improve the resolution and/or sensitivity of ground based telescopes. **4**

Explain why only one of these techniques is useful in improving the resolution and sensitivity of radio telescopes.

(b) (i) Describe the modelling process used in a computer simulation which draws a light curve for an eclipsing binary star system. **2**

(ii) Two stars in a visual binary system have an orbital period of 2.1×10^8 s and are determined to be 7.2×10^8 km apart. **2**

Calculate the combined mass of the stars.

(iii) The spectra below show absorption lines for a variable pair of spectroscopic binary stars at two different times, Time 1 and Time 2. Each spectrum contains the absorption lines from both stars. **3**

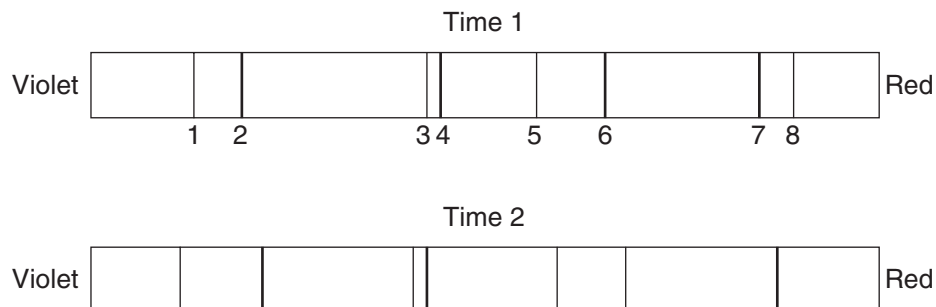

Explain why there are differences in the spectra.

Question 30 continues on page 29

Question 30 (continued)

- (c) (i) A star was found to have a visual magnitude (V) of 2.9 and a photographic magnitude (B) of 4.6. 1

Will the star be more blue or more red in colour?

- (ii) How can the colour index (B–V) of a star be measured in an observatory? 2

- (d) Describe the advantages of using photoelectric technologies over photographic methods in photometry. 3

- (e) A possible evolutionary path of a star is shown on the Hertzsprung-Russell (H-R) diagram. 6

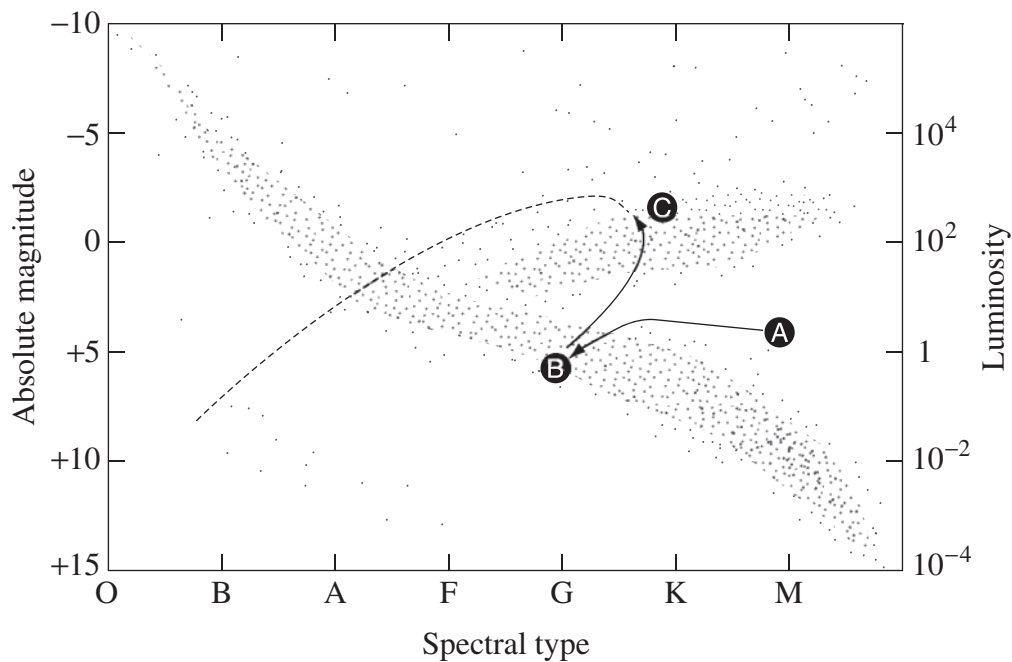

Describe the sequence of events and the associated physical processes a star undergoes in moving from **A** to **B** to **C**.

End of Question 30

Question 31 — From Quanta to Quarks (25 marks)

- (a) Marsden and Geiger conducted an experiment in which they fired alpha particles at a thin gold foil. Most of the particles passed straight through.
- (i) Describe how Rutherford's model of the atom explained these results. **2**
 - (ii) Describe TWO problems associated with Rutherford's model and how these were explained by Bohr's model of the hydrogen atom. **4**
- (b)
- (i) Describe de Broglie's proposal that a particle can exhibit both wave and particle properties. **2**
 - (ii) Explain how Davisson and Germer were able to confirm de Broglie's proposal. **3**
 - (iii) Calculate the velocity of an electron that has a wavelength of 3.33×10^{-10} m. **2**

Question 31 continues on page 31

Question 31 (continued)

- (c) (i) Define *mass defect*. **1**
- (ii) The energy required to separate all the nucleons within a nucleus is the binding energy. The average binding energy per nucleon is a measure of the stability of a nucleus. **2**

The graph shows how average binding energy per nucleon varies with mass number.

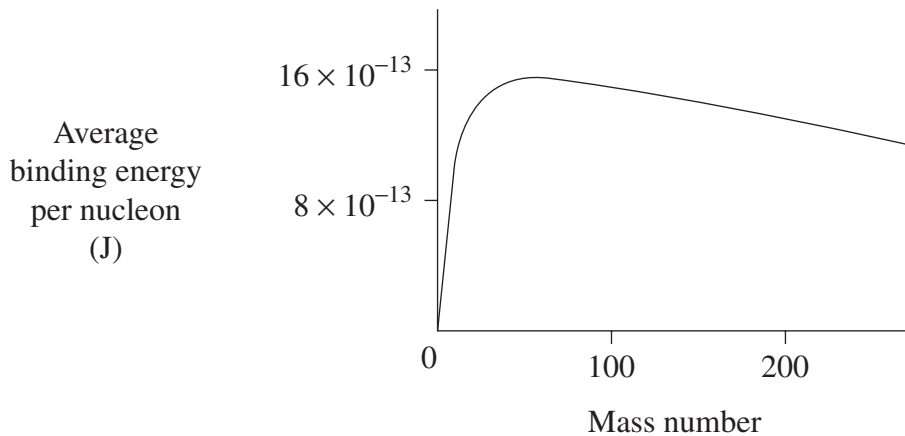

Use the graph to compare the stability of a nucleus of mass number 200 with a nucleus of mass number 50.

- (d) In 1920, Rutherford suggested the existence of an undiscovered nuclear particle. Explain how Chadwick confirmed Rutherford's prediction using conservation laws. **3**
- (e) Theories and experiments not only help increase our understanding but also generate new questions. **6**

Use the standard model of matter to support this statement.

End of Question 31

Question 32 — The Age of Silicon (25 marks)

- (a) The following circuit diagram shows the internal design of a 2-bit analogue to digital converter.

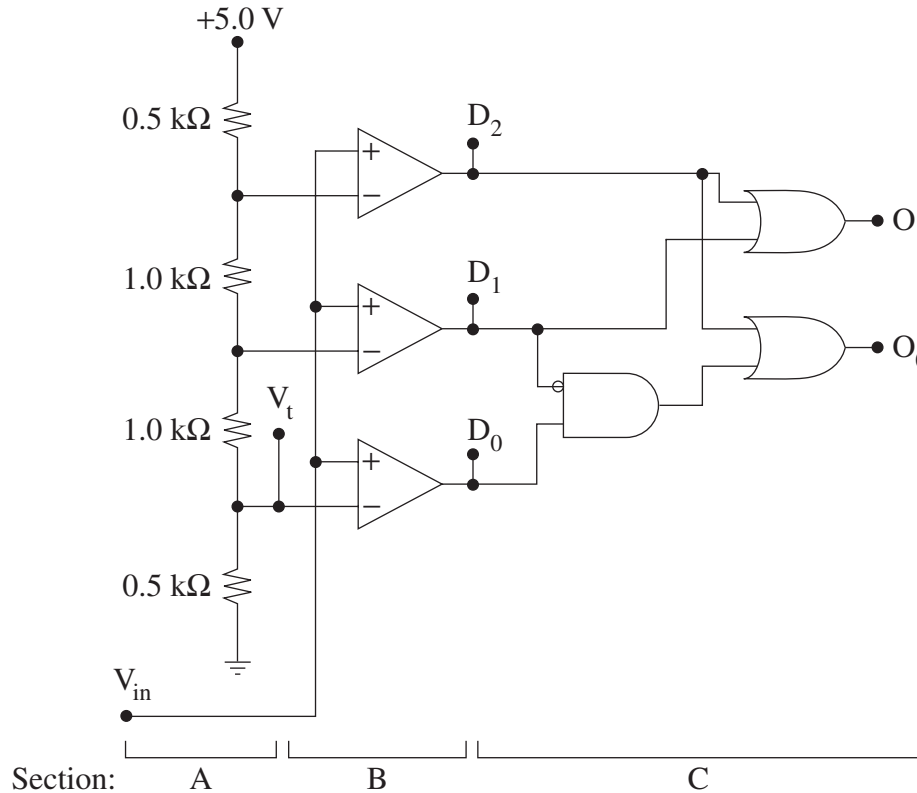

- | | |
|---|----------|
| (i) Identify the function of section A of the circuit. | 1 |
| (ii) Calculate the voltage V_t . | 1 |
| (iii) Are the amplifiers in section B used in an open loop or closed loop configuration? Justify your answer. | 2 |
| (iv) Construct a truth table showing the outputs O_1 and O_0 for each of the possible input states of D_0 , D_1 and D_2 . | 2 |

Question 32 continues on page 33

Question 32 (continued)

- (b) (i) Compare the function of input and output transducers. 2
- (ii) An electronic system monitors conditions in a glasshouse. The system measures sunlight intensity, temperature, and controls an electric watering pump. 5

Copy this table into your writing booklet and complete the table for this system.

	<i>Sunlight</i>	<i>Temperature</i>	<i>Pump</i>
Type of transducer			
Input or output transducer			
Outline of operation	TABLE TO BE COMPLETED IN YOUR WRITING BOOKLET		

- (c) Outline the differences between digital and analogue signals using the operation of a music CD player as an example. 2
- (d) Analyse how the development of the integrated circuit has affected energy consumption. 4
- (e) The advancement of silicon-based integrated circuit technology has resulted in progressive miniaturisation and a doubling of circuit performance roughly every 18 months. It is expected that physics limitations will soon halt this progress, requiring a reconceptualisation of the way integrated circuits are constructed. 6

If this reconceptualisation cannot be realised, what would be the likely impact on society?

End of paper

BLANK PAGE

DATA SHEET

Charge on electron, q_e	$-1.602 \times 10^{-19} \text{ C}$
Mass of electron, m_e	$9.109 \times 10^{-31} \text{ kg}$
Mass of neutron, m_n	$1.675 \times 10^{-27} \text{ kg}$
Mass of proton, m_p	$1.673 \times 10^{-27} \text{ kg}$
Speed of sound in air	340 m s^{-1}
Earth's gravitational acceleration, g	9.8 m s^{-2}
Speed of light, c	$3.00 \times 10^8 \text{ m s}^{-1}$
Magnetic force constant, $\left(k \equiv \frac{\mu_0}{2\pi} \right)$	$2.0 \times 10^{-7} \text{ N A}^{-2}$
Universal gravitational constant, G	$6.67 \times 10^{-11} \text{ N m}^2 \text{ kg}^{-2}$
Mass of Earth	$6.0 \times 10^{24} \text{ kg}$
Planck constant, h	$6.626 \times 10^{-34} \text{ J s}$
Rydberg constant, R (hydrogen)	$1.097 \times 10^7 \text{ m}^{-1}$
Atomic mass unit, u	$1.661 \times 10^{-27} \text{ kg}$ $931.5 \text{ MeV}/c^2$
1 eV	$1.602 \times 10^{-19} \text{ J}$
Density of water, ρ	$1.00 \times 10^3 \text{ kg m}^{-3}$
Specific heat capacity of water	$4.18 \times 10^3 \text{ J kg}^{-1} \text{ K}^{-1}$

FORMULAE SHEET

$$v = f\lambda$$

$$I \propto \frac{1}{d^2}$$

$$\frac{v_1}{v_2} = \frac{\sin i}{\sin r}$$

$$E = \frac{F}{q}$$

$$R = \frac{V}{I}$$

$$P = VI$$

$$\text{Energy} = VIt$$

$$v_{\text{av}} = \frac{\Delta r}{\Delta t}$$

$$a_{\text{av}} = \frac{\Delta v}{\Delta t} \text{ therefore } a_{\text{av}} = \frac{v - u}{t}$$

$$\Sigma F = ma$$

$$F = \frac{mv^2}{r}$$

$$E_k = \frac{1}{2}mv^2$$

$$W = Fs$$

$$p = mv$$

$$\text{Impulse} = Ft$$

$$E_p = -G \frac{m_1 m_2}{r}$$

$$F = mg$$

$$v_x^2 = u_x^2$$

$$v = u + at$$

$$v_y^2 = u_y^2 + 2a_y \Delta y$$

$$\Delta x = u_x t$$

$$\Delta y = u_y t + \frac{1}{2} a_y t^2$$

$$\frac{r^3}{T^2} = \frac{GM}{4\pi^2}$$

$$F = \frac{Gm_1 m_2}{d^2}$$

$$E = mc^2$$

$$l_v = l_0 \sqrt{1 - \frac{v^2}{c^2}}$$

$$t_v = \frac{t_0}{\sqrt{1 - \frac{v^2}{c^2}}}$$

$$m_v = \frac{m_0}{\sqrt{1 - \frac{v^2}{c^2}}}$$

FORMULAE SHEET

$$\frac{F}{l} = k \frac{I_1 I_2}{d}$$

$$d = \frac{1}{p}$$

$$F = BIl \sin \theta$$

$$M = m - 5 \log \left(\frac{d}{10} \right)$$

$$\tau = Fd$$

$$\frac{I_A}{I_B} = 100^{(m_B - m_A)/5}$$

$$\tau = nBIA \cos \theta$$

$$m_1 + m_2 = \frac{4\pi^2 r^3}{GT^2}$$

$$\frac{V_p}{V_s} = \frac{n_p}{n_s}$$

$$F = qvB \sin \theta$$

$$\frac{1}{\lambda} = R \left(\frac{1}{n_f^2} - \frac{1}{n_i^2} \right)$$

$$E = \frac{V}{d}$$

$$\lambda = \frac{h}{mv}$$

$$E = hf$$

$$c = f\lambda$$

$$A_0 = \frac{V_{\text{out}}}{V_{\text{in}}}$$

$$Z = \rho v$$

$$\frac{V_{\text{out}}}{V_{\text{in}}} = - \frac{R_f}{R_i}$$

$$\frac{I_r}{I_0} = \frac{[Z_2 - Z_1]^2}{[Z_2 + Z_1]^2}$$

PERIODIC TABLE OF THE ELEMENTS

1 H 1.008 Hydrogen		4 Be 9.012 Beryllium		12 Mg 24.31 Magnesium		20 Ca 40.08 Calcium		38 Sr 87.62 Strontium		56 Ba 137.3 Barium		88 Ra [226] Radium		2 He 4.003 Helium	
3 Li 6.941 Lithium		11 Na 22.99 Sodium		19 K 39.10 Potassium		37 Rb 85.47 Rubidium		55 Cs 132.9 Caesium		87 Fr [223] Francium		10 Ne 20.18 Neon		18 Ar 39.95 Argon	
21 Sc 44.96 Scandium		39 Y 88.91 Yttrium		57-71 Lanthanoids		89-103 Actinoids		79 Au 197.0 Gold		77 Ir 192.2 Iridium		75 Re 186.2 Rhenium		73 Ta 180.9 Tantalum	
22 Ti 47.87 Titanium		40 Zr 91.22 Zirconium		72 Hf 178.5 Hafnium		74 W 183.8 Tungsten		76 Os 190.2 Osmium		78 Pt 195.1 Platinum		80 Hg 200.6 Mercury		82 Pb 207.2 Lead	
23 V 50.94 Vanadium		41 Nb 92.91 Niobium		73 Ta 180.9 Tantalum		75 Re 186.2 Rhenium		77 Ir 192.2 Iridium		79 Au 197.0 Gold		81 Tl 204.4 Thallium		83 Bi 209.0 Bismuth	
24 Cr 52.00 Chromium		42 Mo 95.94 Molybdenum		74 W 183.8 Tungsten		76 Os 190.2 Osmium		78 Pt 195.1 Platinum		80 Hg 200.6 Mercury		82 Pb 207.2 Lead		84 Po [209.0] Polonium	
25 Mn 54.94 Manganese		43 Tc [97.91] Technetium		75 Re 186.2 Rhenium		77 Ir 192.2 Iridium		79 Au 197.0 Gold		81 Tl 204.4 Thallium		83 Bi 209.0 Bismuth		85 At [210.0] Astatine	
26 Fe 55.85 Iron		44 Ru 101.1 Ruthenium		76 Os 190.2 Osmium		78 Pt 195.1 Platinum		80 Hg 200.6 Mercury		82 Pb 207.2 Lead		84 Po [209.0] Polonium		86 Rn [222.0] Radon	
27 Co 58.93 Cobalt		45 Rh 102.9 Rhodium		77 Ir 192.2 Iridium		79 Au 197.0 Gold		81 Tl 204.4 Thallium		83 Bi 209.0 Bismuth		85 At [210.0] Astatine		87 Fr [223] Francium	
28 Ni 58.69 Nickel		46 Pd 106.4 Palladium		78 Pt 195.1 Platinum		80 Hg 200.6 Mercury		82 Pb 207.2 Lead		84 Po [209.0] Polonium		86 Rn [222.0] Radon		88 Ra [226] Radium	
29 Cu 63.55 Copper		47 Ag 107.9 Silver		79 Au 197.0 Gold		81 Tl 204.4 Thallium		83 Bi 209.0 Bismuth		85 At [210.0] Astatine		87 Fr [223] Francium		89 Ac [227] Actinium	
30 Zn 65.41 Zinc		48 Cd 112.4 Cadmium		80 Hg 200.6 Mercury		82 Pb 207.2 Lead		84 Po [209.0] Polonium		86 Rn [222.0] Radon		88 Ra [226] Radium		90 Th 232.0 Thorium	
31 Ga 69.72 Gallium		49 In 114.8 Indium		81 Tl 204.4 Thallium		83 Bi 209.0 Bismuth		85 At [210.0] Astatine		87 Fr [223] Francium		89 Ac [227] Actinium		91 Pa 231.0 Protactinium	
32 Ge 72.64 Germanium		50 Sn 118.7 Tin		82 Pb 207.2 Lead		84 Po [209.0] Polonium		86 Rn [222.0] Radon		88 Ra [226] Radium		90 Th 232.0 Thorium		92 U 238.0 Uranium	
33 As 74.92 Arsenic		51 Sb 121.8 Antimony		83 Bi 209.0 Bismuth		85 At [210.0] Astatine		87 Fr [223] Francium		89 Ac [227] Actinium		91 Pa 231.0 Protactinium		93 Np [237] Neptunium	
34 Se 78.96 Selenium		52 Te 127.6 Tellurium		84 Po [209.0] Polonium		86 Rn [222.0] Radon		88 Ra [226] Radium		90 Th 232.0 Thorium		92 U 238.0 Uranium		94 Pu [244] Plutonium	
35 Br 79.90 Bromine		53 I 126.9 Iodine		85 At [210.0] Astatine		87 Fr [223] Francium		89 Ac [227] Actinium		91 Pa 231.0 Protactinium		93 Np [237] Neptunium		95 Am [243] Americium	
36 Kr 83.80 Krypton		54 Xe 131.3 Xenon		86 Rn [222.0] Radon		88 Ra [226] Radium		90 Th 232.0 Thorium		92 U 238.0 Uranium		94 Pu [244] Plutonium		96 Cm [247] Curium	
37 Rb 85.47 Rubidium		55 Cs 132.9 Caesium		87 Fr [223] Francium		89 Ac [227] Actinium		91 Pa 231.0 Protactinium		93 Np [237] Neptunium		95 Am [243] Americium		97 Bk [247] Berkelium	
38 Sr 87.62 Strontium		56 Ba 137.3 Barium		88 Ra [226] Radium		90 Th 232.0 Thorium		92 U 238.0 Uranium		94 Pu [244] Plutonium		96 Cm [247] Curium		98 Cf [251] Californium	
39 Y 88.91 Yttrium		57-71 Lanthanoids		89-103 Actinoids		79 Au 197.0 Gold		81 Tl 204.4 Thallium		83 Bi 209.0 Bismuth		85 At [210.0] Astatine		87 Fr [223] Francium	
40 Zr 91.22 Zirconium		72 Hf 178.5 Hafnium		74 W 183.8 Tungsten		76 Os 190.2 Osmium		78 Pt 195.1 Platinum		80 Hg 200.6 Mercury		82 Pb 207.2 Lead		84 Po [209.0] Polonium	
41 Nb 92.91 Niobium		73 Ta 180.9 Tantalum		75 Re 186.2 Rhenium		77 Ir 192.2 Iridium		79 Au 197.0 Gold		81 Tl 204.4 Thallium		83 Bi 209.0 Bismuth		85 At [210.0] Astatine	
42 Mo 95.94 Molybdenum		74 W 183.8 Tungsten		76 Os 190.2 Osmium		78 Pt 195.1 Platinum		80 Hg 200.6 Mercury		82 Pb 207.2 Lead		84 Po [209.0] Polonium		86 Rn [222.0] Radon	
43 Tc [97.91] Technetium		75 Re 186.2 Rhenium		77 Ir 192.2 Iridium		79 Au 197.0 Gold		81 Tl 204.4 Thallium		83 Bi 209.0 Bismuth		85 At [210.0] Astatine		87 Fr [223] Francium	
44 Ru 101.1 Ruthenium		76 Os 190.2 Osmium		78 Pt 195.1 Platinum		80 Hg 200.6 Mercury		82 Pb 207.2 Lead		84 Po [209.0] Polonium		86 Rn [222.0] Radon		88 Ra [226] Radium	
45 Rh 102.9 Rhodium		77 Ir 192.2 Iridium		79 Au 197.0 Gold		81 Tl 204.4 Thallium		83 Bi 209.0 Bismuth		85 At [210.0] Astatine		87 Fr [223] Francium		89 Ac [227] Actinium	
46 Pd 106.4 Palladium		78 Pt 195.1 Platinum		80 Hg 200.6 Mercury		82 Pb 207.2 Lead		84 Po [209.0] Polonium		86 Rn [222.0] Radon		88 Ra [226] Radium		90 Th 232.0 Thorium	
47 Ag 107.9 Silver		79 Au 197.0 Gold		81 Tl 204.4 Thallium		83 Bi 209.0 Bismuth		85 At [210.0] Astatine		87 Fr [223] Francium		89 Ac [227] Actinium		91 Pa 231.0 Protactinium	
48 Cd 112.4 Cadmium		80 Hg 200.6 Mercury		82 Pb 207.2 Lead		84 Po [209.0] Polonium		86 Rn [222.0] Radon		88 Ra [226] Radium		90 Th 232.0 Thorium		92 U 238.0 Uranium	
49 In 114.8 Indium		81 Tl 204.4 Thallium		83 Bi 209.0 Bismuth		85 At [210.0] Astatine		87 Fr [223] Francium		89 Ac [227] Actinium		91 Pa 231.0 Protactinium		93 Np [237] Neptunium	
50 Sn 118.7 Tin		82 Pb 207.2 Lead		84 Po [209.0] Polonium		86 Rn [222.0] Radon		88 Ra [226] Radium		90 Th 232.0 Thorium		92 U 238.0 Uranium		94 Pu [244] Plutonium	
51 Sb 121.8 Antimony		83 Bi 209.0 Bismuth		85 At [210.0] Astatine		87 Fr [223] Francium		89 Ac [227] Actinium		91 Pa 231.0 Protactinium		93 Np [237] Neptunium		95 Am [243] Americium	
52 Te 127.6 Tellurium		84 Po [209.0] Polonium		86 Rn [222.0] Radon		88 Ra [226] Radium		90 Th 232.0 Thorium		92 U 238.0 Uranium		94 Pu [244] Plutonium		96 Cm [247] Curium	
53 I 126.9 Iodine		85 At [210.0] Astatine		87 Fr [223] Francium		89 Ac [227] Actinium		91 Pa 231.0 Protactinium		93 Np [237] Neptunium		95 Am [243] Americium		97 Bk [247] Berkelium	
54 Xe 131.3 Xenon		86 Rn [222.0] Radon		88 Ra [226] Radium		90 Th 232.0 Thorium		92 U 238.0 Uranium		94 Pu [244] Plutonium		96 Cm [247] Curium		98 Cf [251] Californium	
55 Cs 132.9 Caesium		87 Fr [223] Francium		89 Ac [227] Actinium		91 Pa 231.0 Protactinium		93 Np [237] Neptunium		95 Am [243] Americium		97 Bk [247] Berkelium		99 Es [252] Einsteinium	
56 Ba 137.3 Barium		88 Ra [226] Radium		90 Th 232.0 Thorium		92 U 238.0 Uranium		94 Pu [244] Plutonium		96 Cm [247] Curium		98 Cf [251] Californium		100 Fm [257] Fermium	
57-71 Lanthanoids		72 Hf 178.5 Hafnium		74 W 183.8 Tungsten		76 Os 190.2 Osmium		78 Pt 195.1 Platinum		80 Hg 200.6 Mercury		82 Pb 207.2 Lead		84 Po [209.0] Polonium	
72 Hf 178.5 Hafnium		74 W 183.8 Tungsten		76 Os 190.2 Osmium		78 Pt 195.1 Platinum		80 Hg 200.6 Mercury		82 Pb 207.2 Lead		84 Po [209.0] Polonium		86 Rn [222.0] Radon	
73 Ta 180.9 Tantalum		75 Re 186.2 Rhenium		77 Ir 192.2 Iridium		79 Au 197.0 Gold		81 Tl 204.4 Thallium		83 Bi 209.0 Bismuth		85 At [210.0] Astatine		87 Fr [223] Francium	
74 W 183.8 Tungsten		76 Os 190.2 Osmium		78 Pt 195.1 Platinum		80 Hg 200.6 Mercury		82 Pb 207.2 Lead		84 Po [209.0] Polonium		86 Rn [222.0] Radon		88 Ra [226] Radium	
75 Re 186.2 Rhenium		77 Ir 192.2 Iridium		79 Au 197.0 Gold		81 Tl 204.4 Thallium		83 Bi 209.0 Bismuth		85 At [210.0] Astatine		87 Fr [223] Francium		89 Ac [227] Actinium	
76 Os 190.2 Osmium		78 Pt 195.1 Platinum		80 Hg 200.6 Mercury		82 Pb 207.2 Lead		84 Po [209.0] Polonium		86 Rn [222.0] Radon		88 Ra [226] Radium		90 Th 232.0 Thorium	
77 Ir 192.2 Iridium		79 Au 197.0 Gold		81 Tl 204.4 Thallium		83 Bi 209.0 Bismuth		85 At [210.0] Astatine		87 Fr [223] Francium		89 Ac [227] Actinium		91 Pa 231.0 Protactinium	
78 Pt 195.1 Platinum		80 Hg 200.6 Mercury		82 Pb 207.2 Lead		84 Po [209.0] Polonium									